

# RENEWABLE ENERGY



## STATE OF THE ART TECHNOLOGY FOR WIND ENERGY

### NEW CHALLENGES IN WIND POWER GENERATION

During the latest years, wind power have had an extremely important development, assuming a growing importance in the global energy scenario.

The challenges that wind energy producers are facing essentially consist in the possibility of further generated kWh cost reduction and in being able to meet higher and higher quality standards of the power to be supplied.

At the same time we are witnesses of a continuous growth in size of wind generators and a growing focus on innovative technological solution.

EEl offers a wide range of tailored solutions for the connection to the grid of wind turbines with output power up to 3 MW

Main characteristics of EEl converters are:

**Efficiency:** IGBT PWM inverter and Active Front End,

**Reliability:** Only thin film DC link capacitors and modular design for easier maintenance operations

**Safety:** self-protection functions, IGBT trigger by Optical Fiber

**Quality in energy production:** low THD(I), adjustable power factor, LVRT capability.

**Flexibility:** state-of-the-art solution, developed and designed according to customer needing

### THREE LEVEL INVERTER

EEl has developed a new series of inverters for grid connection of wind generators based on a modulation technology at three levels. In this way, it is possible to obtain a conversion with a better reconstruction of the sinusoid and a reduction in current harmonics.

Other advantages related to this solution are:

- fewer losses related to IGBT switching
- lower current ripple
- better heat rejection
- higher efficiency.

EEl three-levels inverters for wind application are especially designed for systems with Permanent Magnet Synchronous Generators.



### 2WIND

The 2Wind is a new turbine solution resulting from the cooperation of two leaders in the global energy market: EEl and Sicme Motori. It is the optimum electrical solution through the combination of extensive design experience and successful installations.

2wind offers the energy market an integrated, reliable and competitive solution for power generating turbines.



EEl - Equipaggiamenti Elettronici Industriali - Viale dell'Industria, 37 - 36100 Vicenza - Italy  
Tel. +39 0444 562988 - Fax. +39 0444 562373 - e-mail: info@eei.it - [www.eei.it](http://www.eei.it)

## SOLUTION FOR EVERY APPLICATION

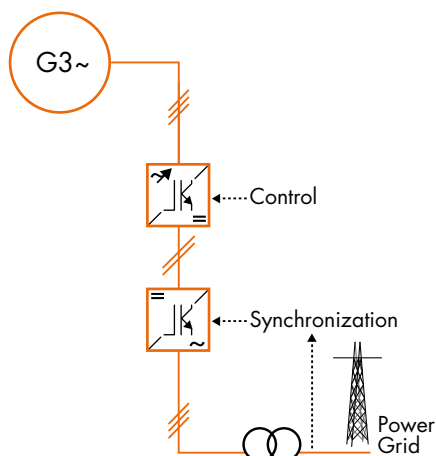

### EEI Converter for Direct Drive PM Generator

In the field of wind generating systems, a very performing solution is based on variable speed turbines equipped with a Direct Drive Permanent Magnet Synchronous Generator (PMSG) without installation of the gearbox. The system is based on a PWM inverter and an AFE (Active Front End) interfacing to the power grid.

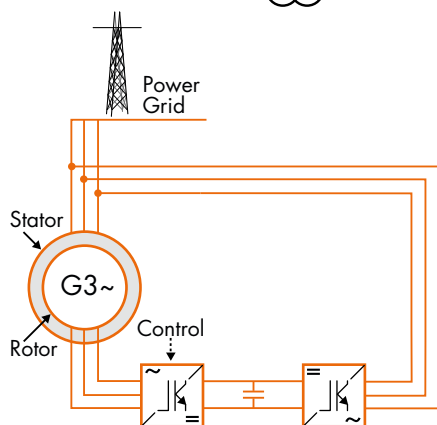

### Double Fed DFIG

In the field of wind energy generating systems, this high performing solution is based on the application of variable speed turbines equipped with a, Double Fed Induction Generator, (DFIG) where:

- the generator's stator is directly connected to the three-phase power grid
  - the control system, constituted by a PWM inverter and an AFE (Active Front End) interfacing with the power grid, is connected to the rotor.
- Furthermore, the separate control for the active and reactive power makes possible the adjustment of the power factor towards the grid through the inverter for the rotor or through the AFE.

Main technical parameters for EEI conversion system are

Matched generator rated power	500kW - 3000kW
Altitude	0 ÷ 3000m (above 1000m the current is derated)
Operation ambient temperature	0 ÷ +50 °C (above +40 °C the current is derated)
Storage ambient temperature	-40 ÷ +70 °C
Cooling	Forced air or water cooling
Efficiency	> 97%
Noise	< 82 dB
Protection degree	IP23
Protection functions	Grid-dip, Grid-side lightning, Communication port, User port lightning, Overspeed, Underspeed, Overfrequency, Underfrequency, AC overvoltage, AC undervoltage, DC overvoltage, DC undervoltage, Short circuit, Earth fault, Stator overcurrent, Overtemperature, Overhumidity, Communication fault
Voltage range	400V or 690Vac (3 phase) +-10%
Power Factor	Adjustable – Typical Power Factor = 1
Frequency range	50/60 Hz ±5%
Rated current	500A - 3000A
Overload capability	150%
Dimensions (W x H x D) mm	1600 x 2200 x 1000 2600 x 2200 x 1000

EEI srl reserves the right to make any changes to the catalogue and products illustrated in it without any advance notice. Any brands mentioned are the property of the manufacturers.