

EEL ET9 SERIES

DC CABINET FOR INDUSTRY

EEL Turn-key cabinet solution for 2Q / 4Q drive for a single DC motor applications.

MAIN FEATURES

- Drives with SCR or IGBT power circuit
- Low inductance connections
- HMI with embedded data-logger for local data storage and remote control
- Air cooled

MOTOR CONTROL

- Close loop speed control
- Armature Voltage control
- Current predictive control

MAIN COMPONENTS INCLUDED IN THE CABINET:

- Main circuit breaker
- EMC filter
- Set of HS fuses
- Static pre-charge circuit
- AC line filter
- Bar discharger module
- Motor side inductor
- Active conversion unit
- Set of transformers and power supply for auxiliary circuits
- Set of relays and electronic cards
- HMI touch-panel.



MODULAR

Modular design permits compact solution



ADVANCED

Flexible software configuration allow wide functionalities



READY

Turn-key cabinet solution with easy accessibility and maintainance



RELIABLE & EFFICIENT

Equipped with latest power technology, robust design and energy saving



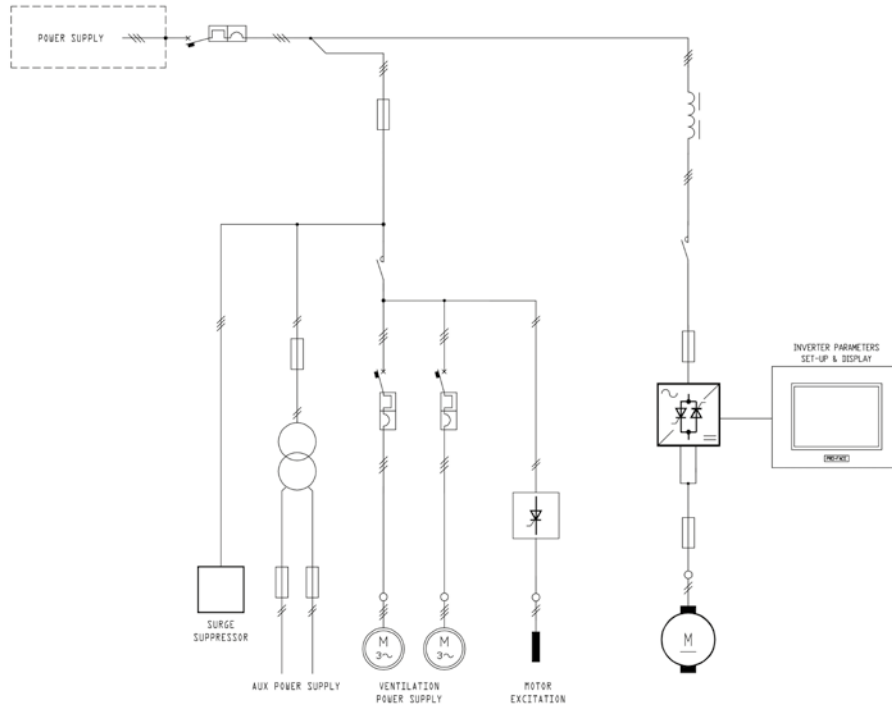
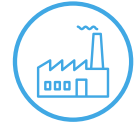

NORMAL DUTY

DIMENSIONS (mm)

MODEL	I Nom.(A)	P Nom. At 500v. (Kw)	P Nom. At 600v (Kw)	I Field (A)	L	H	D
9T0140X	140	70	84	15	800	2000	600
9T0300X	300	150	180	15	800	2000	600
9T0450X	450	235	270	25	800	2200	600
9T0700X	700	350	420	25	800	2200	600
9T01250X	1250	625	750	40	1400	2200	750
9T02000X	2000	1000	1200	40	1400	2200	750

VOLTAGE RANGE : 400 VAC

*FOR OTHERS POWER SIZE PLEASE CONTACT EEI STAFF

EEI - Equipaggiamenti Elettronici Industriali S.p.A.
 T +39.0444.562988 | F +39.0444.562373 (6 linee r.a.) | @ staff@eei.it

www.eei.it

